

Coin & Spline Seals

Roman Global Resources is tooled on the most popular sizes of the Coin & Spline seal line of fastener seals and we can provide many metal/rubber combinations for industrial and aerospace applications.

Coin & Spline (CS) seals are reusable fastener seals designed to seal under the head of fasteners. The rubber on the inner diameter of the parts is chosen to best meet each application requirement and create a durable resilient seal. The rubber is then molded on to the retainer, which provides a metal force-transfer-path to ensure long term torque retention on your fasteners. The coin & spline configuration provides a mechanical metal/rubber bond and the resulting fastener seal is robust, durable and easy to install.

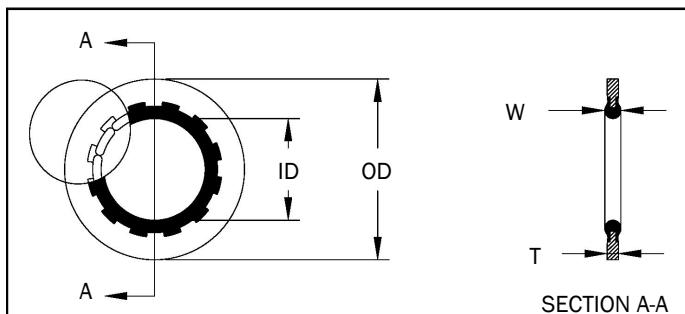

All dimensions listed above are in inches. Sizes listed are the sizes currently available from RGR.

C&S (size)	OD (+/- .010)	ID (+/- .010)	T (+/- .005)	W (+/- .005)
#4	.317	.100	.027	.038
#6	.385	.130	.040	.050
#8	.385	.156	.040	.050
#10	.443	.180	.050	.072
#10 O/S	.468	.186	.050	.072
1/4	.505	.240	.050	.072
1/4 O/S	.531	.245	.050	.072
5/16	.603	.301	.050	.072
3/8	.666	.364	.050	.072
7/16	.760	.427	.050	.072
1/2	.880	.490	.050	.072
9/16	1.067	.552	.050	.072
5/8	1.193	.615	.050	.072
11/16	1.260	.674	.050	.072
3/4	1.322	.740	.064*	.096
7/8	1.510	.864	.064*	.096
1"	1.760	.988	.064*	.096

* Retainer thickness for Stainless Steel to be 0.062±.005

RGR Part Number	Ref. PNs (Parker)	Rubber	Metal
CS-CN16- (size)	600-0002- (size)	Nitrile, General Purpose	Low carbon steel, Zinc plated
CS-CN15- (size)	600-0102- (size)	Nitrile per MIL-PRF-6855, Class 1, Grade 60	Low carbon steel, Zinc plated
CS-AS71- (size)	600-0615- (size)	Silicone per AMS 3304	7075-T6 AL per AMS-QQ-A-250/12, Anodized per MIL-A-8625, Type II, Class 1
CS-SV46- (size)	600-3130- (size)	Fluorocarbon per AMS 3216*	304 Stainless Steel per AMS 5513, Passivate per AMS2700
CS-ML46- (size)	600-6042- (size)	Fluorosilicone per AMS-R-25988, Type 1, Class 1, Grade 60	4130 Cr-Moly Steel per AMS 6350, Cadmium plated per AMS-QQ-P-416, Type II, Class 2, black
CS-CE56- (size)	600-8100- (size)	EPDM, General Purpose	Low carbon steel, Cadmium plated

* Parker Fluorocarbon is certified to AMS 7276 for this part number.

The combinations listed above are just a sample of the material combinations available for the coin & spline seals. All metal and rubber materials listed above can be combined to meet your specific application needs. Please contact us for information on your particular sealing requirements.

Thread Seals

Roman Global Resources is tooled on the most popular sizes of the coin & spline Thread seal line of fastener seals and we can provide many metal/ rubber combinations for industrial and aerospace applications.

Thread seals (TR) are reusable fastener seals designed to seal all leak paths on a threaded fastener. They are usually installed on the nut side of a fastener and create a seal against the nut, the mating hardware and the spiral leak path through the thread helix. One of the three wedges on the ID of the thread seal will always be in position to seal the V-shaped groove that forms the thread pattern on the fastener. Thread seals are self centering, easy to install and reusable if not damaged during installation.

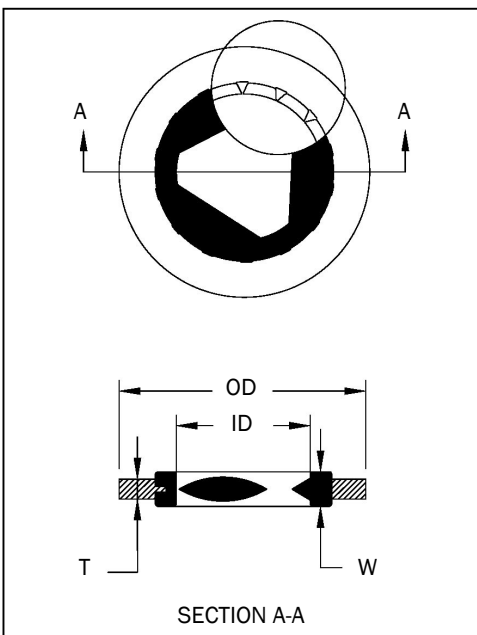

THREAD SEAL (size)	OD (+/- .010)	ID (+/- .010)	T (+/- .005)	W (+/- .005)
#6	.406	.141	.050	.078
#8	.406	.167	.050	.078
#10	.469	.194	.050	.086
1/4	.562	.255	.050	.092
5/16	.687	.319	.064	.107
3/8	.750	.383	.064	.113
1/2	1.000	.510	.078	.140
5/8	1.187	.638	.094	.165
1"	1.750	1.020	.120	.246

All dimensions listed above are in inches. Sizes listed are the sizes currently available from RGR.

Roman Seals PN	Reference PNs ^{Parker}	Rubber	Metal
TR-CN17-(size)	750-0002-(size)	Nitrile, General Purpose	Zinc Plated Steel
TR-CN57-(size)	750-0000-(size) 7500-(size)	Nitrile, General Purpose	Cadmium Plated Steel

The combinations listed above are just a sample of the materials available for thread seals. We have a wide variety of material combinations available to meet your specific application needs. Please call or e-mail us for a quote on your particular sealing requirements.